

# FELSA

---

## SWISS S.A.

Fabrique d'Ebauches Leschot S.A.

### **CAL. 715.007**

**AUTOMATIC, DATE AND TWO TIME ZONE  
21 JEWELS – SWISS MADE**

**Lever movement, sweep second with self-winding mechanism, jewel bearing,  
date and two time zone indicator, frequency 4 Hz  
(28'800 A/h 'vibrations per hour').**

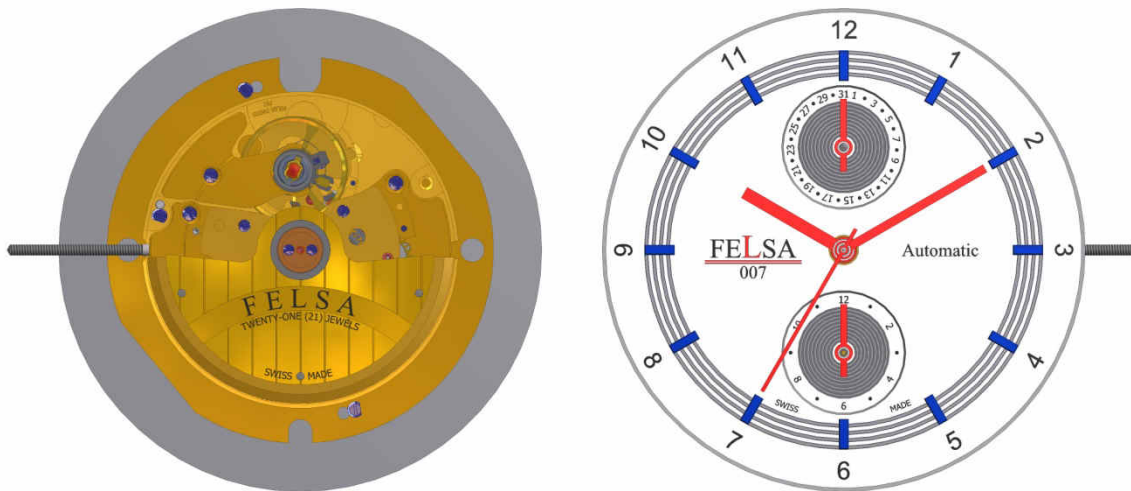

### **TECHNICAL SPECIFICATIONS**

1. Outside Diameter	: 32.00 mm
2. Casing Diameter	: 25.60 mm
3. Stem height / Thickness	: 2.25 mm / 4.85 mm
4. Frequency	: 4Hz; 28'800 beats per hour
5. Power Reserver	: mini. 42 hours
6. Accuracy	: -5 /+20 sec per day
7. Jewels	: 21
8. Shock absorbing devices	: 2
9. Amplitude	: T24 mini. 200°
10. Winding / Settings 2 positions	: 1) winding; 2) time setting

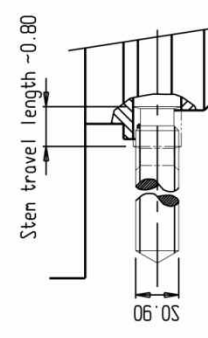
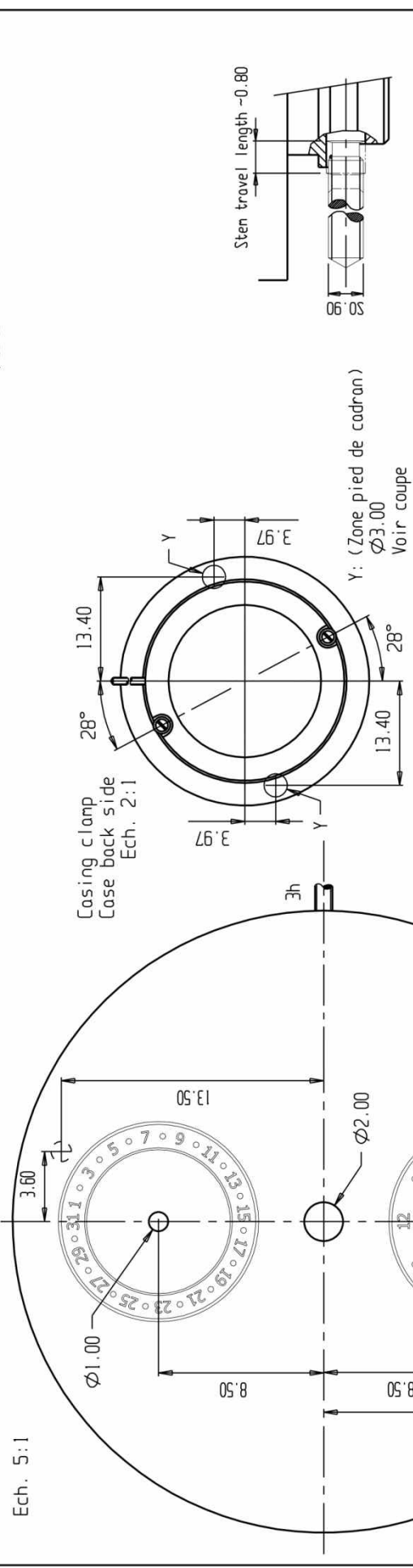
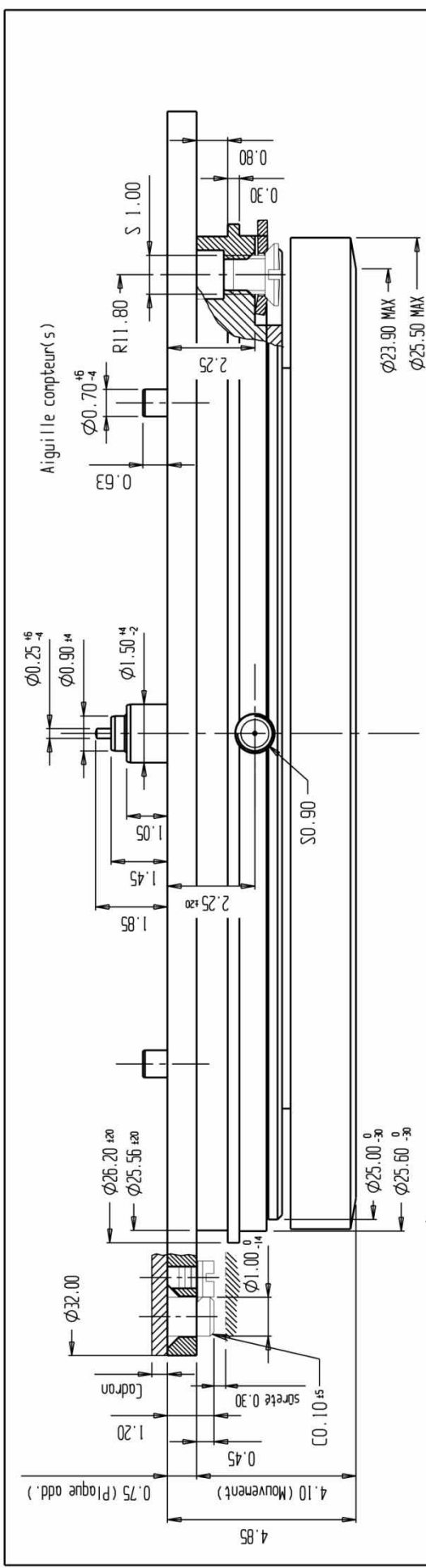

CORRECTIONS		Matière et traitement :		Echelle		Nb. P.C.	
No	DECISIONS/DATE	VISA		10:1		1	
01	Détail pied cadran	K.R		COTES EN MILLIMETRES			
				TOLERANCES EN MICRONS			
				DIVERS : Tol.générale ± 10			
Cage pour boîte				CAL	DATE	VISA	
Frame for case				715	07.12.16	K.R	
PLAN/DWG CK/Edité				PIECE	No/PART	No EXEC	CODEF
71590HAB01				FIELSA		71590000	07
Fabrique d'Ebauches Leschat S.A.							